



Electrically Trace Heated Pipe-in-Pipe *under way*

see page 3 for more details

What's inside...

- 02 High-Performance Pipe-in-Pipe
- 04 Riser developments
- 06 Composite materials
- 07 High-technology Aasta Hansteen
- 08 By-Pass Purge Welding System
- 09 Welding qualification for reelable high-strength steels
- 10 Next-generation Bundle technology
- 11 High-strength Mechanically Lined Pipe
- 12 Fleet update
- 14 Heaviest subsea lift
- 15 AIV: a game-changing technology
- 16 Semi-automatic piggyback clamping



In-depth technology news

More than ever before, the oil and gas industry recognises that technological innovation is the key to exploiting complex new discoveries and extending the productive life of existing fields.

This has been described as the era of “high IQ per barrel”, and companies like ours have a responsibility to innovate, collaborate and open our doors and minds to enable our clients to achieve their goals.

For many years, Subsea 7 has researched and investigated subsea industry technology requirements, and, in this publication, you can read about the progress of some of the concepts that we have conceived, commercialised and are applying in client projects.

We are committed to effective technology development. We work in successful collaboration with many clients and development partners, and we apply our technological expertise through a number of global internal networks throughout our company.

We hope that the technologies profiled in these pages are of benefit to your planned and current operations. Please don't hesitate to contact us if you would like to explore any areas of mutual technological benefit in more depth.

Dr Stuart N Smith, Vice President Technology & Asset Development
John Mair, Technology Development Director

High-Performance a step-change in thermal

John Mair, Technology Development Director

Over several years, Subsea 7 has undertaken a continuous development programme to bring to the market a step-change technology for the thermal insulation of subsea pipelines.

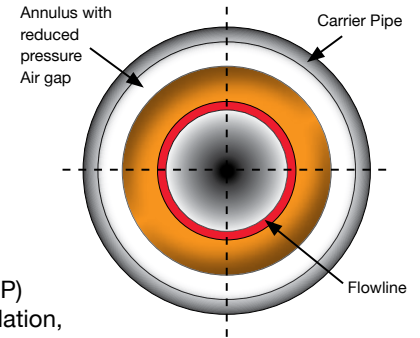

Subsea 7 has an established track record of Pipe-in-Pipe (PIP) design, construction and installation, with over 40 projects executed to date by different installation methods, including J-lay, S-lay, towing and, most recently, reel-lay. To develop the reel-lay solution, we have collaborated with our development partner ITP InTerPipe to qualify the most thermally efficient Pipe-in-Pipe technology in the market.

High-Performance PIP – installation by reel-lay

Initially a series of full-scale thermal performance tests was carried out on a purpose-built rig on a wide range of PIP insulation materials, including measuring the thermal performance before and after the reeling process.

These tests conclusively demonstrated that the ITP PIP technology was superior to other insulation products. This was achieved by using ITP Izoflex™ insulation material installed within the Pipe-in-Pipe annulus with a partial vacuum drawdown and the insulation material acting as a continuous centraliser.

This performance, as illustrated in Figure 1, showing the “no-touch” cool-down time approximately three times better than other products.

Fig 1.

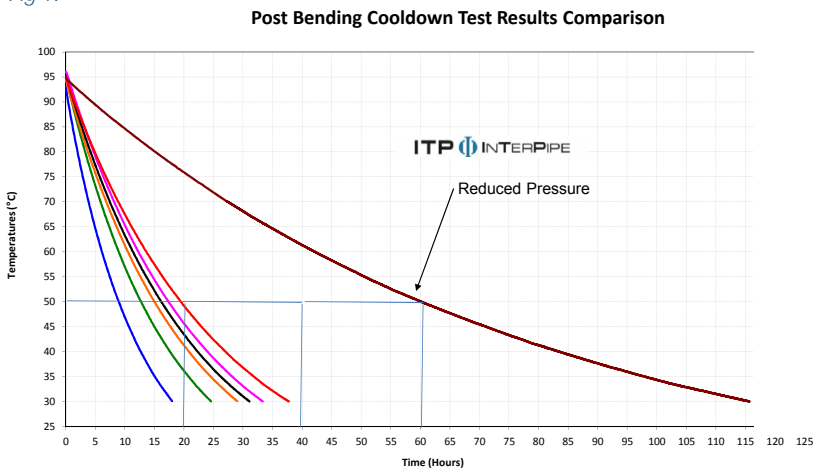

Another benefit is illustrated in Figure 2 (opposite), is that with the High-Performance PIP product, a smaller annulus is required for a given U-value. This has the potential for a smaller outer pipe to be used, resulting in considerable cost savings.

Fig 2.

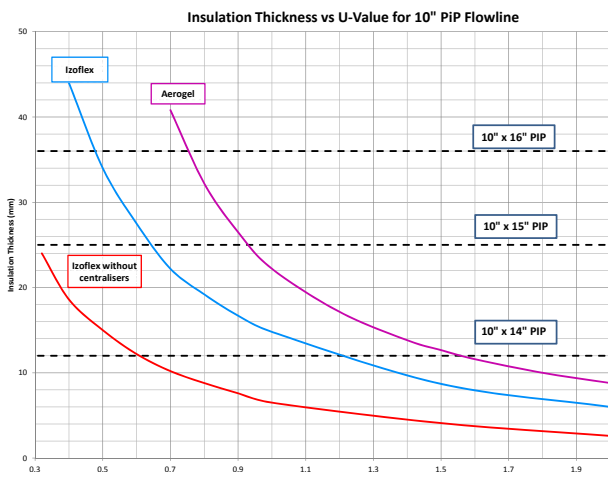

Pipe-in-Pipe: performance

Electrically Trace Heated PIP – installation by reel-lay

Building upon this design, the next phase in the development programme was the qualification and commercialisation of an Electrically Trace Heated option.

Electrically Trace Heated PIP technology combines our High-Performance PIP technology with a low-power electrical heating arrangement to deliver further significantly enhanced flow assurance properties. The electrical heating comprises individual three-phase wiring triplets configured in a star arrangement.

Heating Wire Arrangement

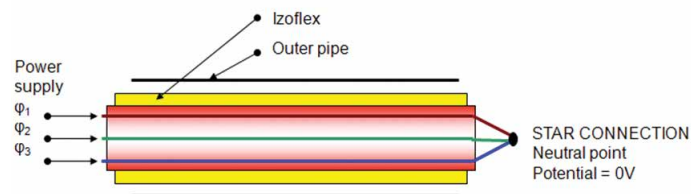

The space available within the annulus enables a number of circuits to be installed, thereby providing a high level of redundancy.

The high level of thermal efficiency of our design provides the further benefit of a low power requirement to meet the specified pipeline heat-up time. This enables a low-voltage system to be adopted with the advantage of longer stepout distance and use of field-proven electrical connectors.

In normal operation, the system provides “no-touch” times of 72 hours or more before the heating system needs to be activated to maintain the flowline above Wax Appearance Temperature (WAT) or Hydrate Appearance Temperature (HAT), with a typical power consumption of 5-10W/m.

The high-specification insulated heating wires, as part of the qualification, have been subjected to accelerated ageing tests and are located in contact with the outside diameter of the inner pipe and held in place by the insulation material.

Finite Element analysis has been performed to evaluate the impact on the wires during the reeling process. This has also been validated by simulated reeling trials to demonstrate that no detrimental impact is experienced.

This development work has been performed in full compliance with DNV Recommended Practice for new technology DNV RP A203, and has culminated in the award of Fitness for Service qualification.

This accreditation provides a high level of confidence to clients who are looking to address flow assurance issues of long shutdown and start-up conditions (e.g. hydrate formation) and enable longer, more cost-effective single-line tie-back distances.



Subsea 7's reel-lay vessel Seven Oceans laying pipe

The interest in High-Performance and Electrically Trace Heated PIP technology is growing, with many operators, including majors and independents, evaluating the potential benefits for their projects.

The nature of the reel-lay installation method is particularly suited to Electrically Trace Heated PIP, since the wires can be installed in long stalks onshore, unlike with J-lay or S-lay.

Subsea 7 has completed an in-depth qualification for Total and is currently working closely with Noble Energy for a deepwater subsea field that would be dependent on Electrically Trace Heated PIP technology for the field development.

An integrated project team has been set up in Houston to complete the detailed engineering and discrete qualification of project-specific elements of the Trace Heating system.

Pipeline fabrication will be performed in one of Subsea 7's spoolbases, with installation planned by our flagship reel-lay vessel, *Seven Oceans*.

Looking to the future, further enhancements of both High-Performance and Electrically Trace Heated PIP may include the incorporation of fibre optic monitoring to track temperature throughout the length of the pipeline.

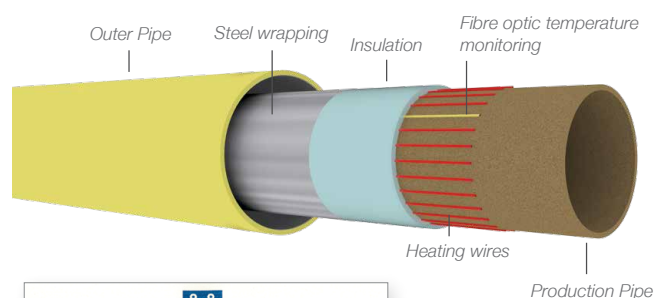

For further information contact John.Mair@subsea7.com

Recent riser developments

Dr Stuart N Smith, Vice President Technology & Asset Development

Over many years, Subsea 7 has developed a unique suite of riser concepts and related technologies to meet a wide range of specific field characteristics, such as water depth, environmental conditions, host specification, hydrocarbon composition and client preferences.

The continuous development of our riser technology is of great strategic importance in enabling our clients to meet the demands associated with ever-increasing challenges of water depth, corrosion, fatigue and harsh environments.

Looking to the future, the growing demand for increased

corrosion resistance, high-pressure capacity requirements and fatigue life is driving the need for new materials. High-strength steels and composite materials such as carbon fibre are now being considered as realistic future technological alternatives to conventional carbon steel. We are actively engaged in developing and qualifying a number of these novel initiatives (see page 6).

The following overview provides an update of Subsea 7 riser developments associated with challenging offshore projects around the world.

Hybrid Riser Tower (HRT)

The Hybrid Riser Tower concept is a complex and effective riser system pioneered by Subsea 7 over 15 years ago to gather all carried fluids for a deepwater or ultra-deepwater field into a vertical bundle for transfer to an FPSO.

Subsea 7 is currently constructing two HRTs in Angola for Total's CLOV project in 1,300m water depth in Block 17. As part of our continuous development programme, we are focussed on four main areas:

- Investigation of the hydrodynamic behaviour which is sensitive to Galloping, VIV and VIM, through Basin test campaigns and CFD computations.

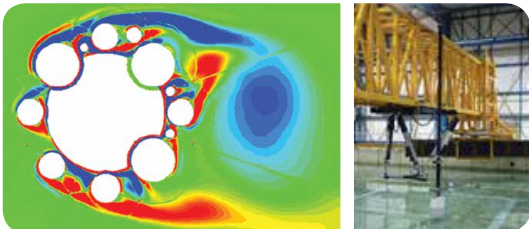

- Investigation of the use of non-metallic materials to save weight and reduce the amount of buoyancy required.

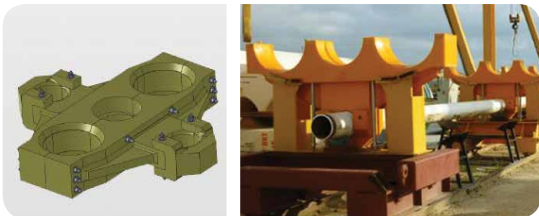

- Review of our design methodology to increase its sensitivity and efficiency by the extensive use of global modelling approaches and fatigue calculations.
- Enhancement of our safety and maintenance performance by developing a top tower diverless connection system for flexible jumpers.

The programme deliverables have already produced benefits on projects such as Total's CLOV project in Angola, where the use of polymer materials has been adopted for the HTR Guiding Frames.

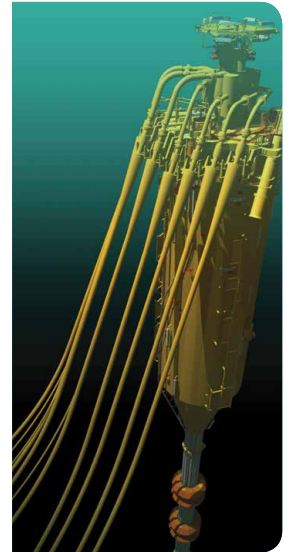

Hybrid Riser Tower

Steel Catenary Risers (SCRs)

Steel Catenary Risers (SCRs) are a preferred riser system for many field developments due to their cost efficiency, ease of installation and track record. Installation can typically be by all three methods available from Subsea 7: J-lay, S-lay and reel-lay.

Subsea 7 installed the first-ever metallurgically clad SCR in Shell's Bonga development offshore Nigeria by the J-lay method, followed by Exxon Mobil's Erha development, also offshore Nigeria. Installation by reel-lay has also been performed in Brazil and the Gulf of Mexico.

The Steel Lazy Wave Riser (SLWR), an innovative derivative of the SCR, was also successfully installed on Shell's BC-10 project off Brazil in 1,800m water depth.

A common requirement of most SCR is the need for the highest quality welding and inspection technology, particularly in the case of installation by reel-lay.

Qualification of the required welding technology for reel-lay was successfully performed by Subsea 7 to confirm:

Buoyancy Supported Riser (BSR)



The scale of Subsea 7's innovative Buoyancy Supported Riser system is clearly seen here during the arrival in Brazil of the first of the large buoys on which the decoupled riser system is based.

The buoys for the Petrobras Guar-Lula NE project in the Santos Basin arrived in the port of So Sebastio from Qingdao Wuchuan Heavy Industry's shipyard in China where they were fabricated. Each buoy measures around 50m by 40m and weighs over 2,500t for the first installation phase of the project, the largest Engineering, Procurement, Installation and Commissioning (EPIC) SURF contract to be awarded to date in Brazil.

The system is designed to accommodate a large numbers of risers in a small area in a decoupled arrangement. In this case, there are twenty-seven 3.9km steel catenary risers, of which eighteen are 7.5-inch production lines, three 9.5-inch water injection lines and six 8-inch gas injection lines.

The SCRs will be fabricated at Subsea 7's spoolbase in Brazil, installed and hooked up by reel-lay to the four subsurface buoys, each of which is tethered by tendons adjusted with a purpose-designed jacking system. The buoys are submerged approximately 250 metres below the surface and are connected to the FPSO by flexible jumpers.



First two Guar-Lula NE buoys arrive at Sao Sebastiao port, Brazil

The BSR system is designed to absorb the dynamics from the FPSO, resulting in reduced dynamic stresses on the SCRs.

With the pre-salt Guar-Lula NE fields lying in depths beyond 2,100m, the production and water injection lines are constructed predominantly from BUTTING BuBi® Mechanically Lined Pipe, and this will be the first time Mechanically Lined Pipe is installed by the reel-lay method anywhere in the world.

The use of Mechanically Lined Pipe resulted in a significant cost and schedule saving, while still being qualified for a dynamic SCR in sour service conditions.

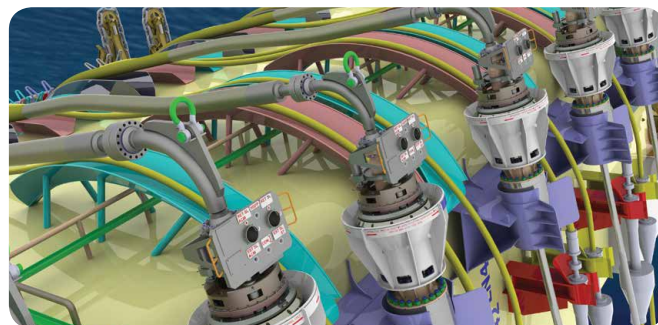

Jumper vertical connectors

- Mechanical and corrosion testing of girth welds met industry standards
- Girth welds are suitable for reeling
- Automated Ultrasonic Testing (AUT) verification
- Girth welds meet or exceed DNV class C/2 fatigue performance.

Shell developed the SLWR concept to improve fatigue performance and to reduce payload on the FPSO turret in ultra-deep water. Buoyancy elements were attached to the

risers in the sag bend region near the TDP along with a 23m long flex-joint assembly to achieve an SLWR configuration that provided better compliance of the riser to FPSO motion responses in harsh environmental conditions, thereby improving fatigue life.

In a recent study, Subsea 7's SLWR experience and Weight Distributed Steel Catenary Riser (WDSCR) technology have been combined to demonstrate that the long low-wave configuration can provide a robust solution for future pre-salt projects in Brazil.

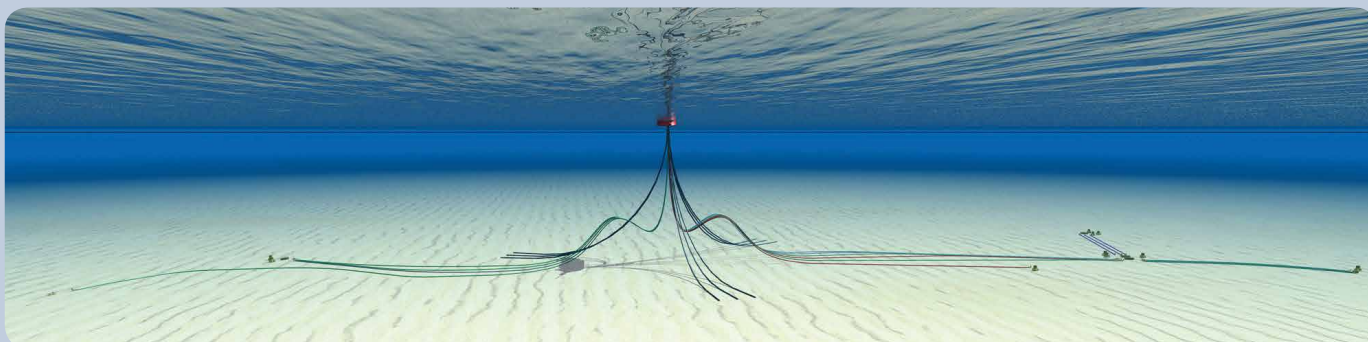

Shell BC10 Lazy Wave Riser configuration

For further information contact Stuart.Smith@subsea7.com

Emerging materials for riser solutions

John Mair, Technology Development Director

The oil and gas industry has widely adopted the use of composites in a variety of applications over the past 20 years, including onshore production piping, fire water pipe and repair. The increasing demands on materials to meet future technical requirements for risers, flowlines, spools and components such as stress joints is leading the industry to take a closer look at composites for these more demanding applications.

Technical specifications to address the requirements associated with pressure, temperature, corrosion and fatigue are stretching the suitability of established metallic and non-bonded flexible options. Bonded composite thermoplastic pipe is a high-end composite solution that directly addresses many of these challenges while delivering substantial reductions in vessel payload.

Subsea 7 has undertaken a number of studies with two of the principal market-leading companies in bonded composite technology, Airborne and Magma, to evaluate the possibilities for this emerging technology, and understand the opportunities and challenges in its design and installation.

A phased approach is also being adopted towards the introduction and potential applications of this technology by a number of operators in order to gain a detailed understanding for its deployment in such demanding emerging applications as deepwater risers. High sour environments and high-temperature applications that could potentially see a significant reduction in top-tension

buoyancy requirements are also issues under consideration.

The riser designs of both Airborne and Magma use bonded composite thermoplastic-based technology.

One area of consistent interest in this technology is for deepwater spools. Spool fatigue is one example where fluctuating flow regimes and riser movement may be better accommodated by the properties of composite products in terms of flexibility and fatigue resistance. A composite spool can more readily accommodate dynamic loads, flex to absorb movement in the riser and flowline and offer opportunities to streamline the deployment and connection approach. Subsea 7 is currently leading studies to assess these potential benefits.

Similarly, at the upper end of the riser, the connection arrangement experiences many of the same challenges. With its superior flexibility and fatigue resistance, bonded composite thermoplastic pipe could be suitable as a taper joint alternative to the conventional flex joint in these increasingly demanding applications.

Subsea 7 has engaged with Magma to qualify its carbon fibre PEEK product, m-pipe®, for a taper joint design specifically for Catenary Riser-type configurations. Magma's choice of premium materials, laser manufacturing process and end-fitting approach align m-pipe® with some of the most demanding design challenges we will face.



m-pipe®

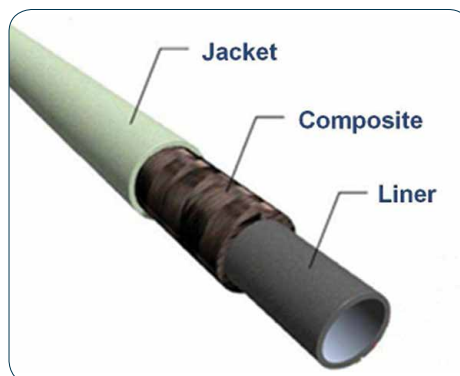

Airborne



Conventional Flex Joint

For further information contact John.Mair@subsea7.com

Deepwater technologies in the Norwegian Sea

Stian Sande, Subsea 7's Aasta Hansteen Project Manager

In early 2013, Subsea 7 was awarded a contract by Statoil for the construction of the Aasta Hansteen gas field in the northern Norwegian Sea, north of the Arctic Circle, in water depths of 1,300m.

As well as being the deepest development in the Norwegian Sea, and involving the installation of the world's largest SPAR gas platform, Aasta Hansteen is a technology-driven development that includes two notable "firsts" for Subsea 7 in the harsh environment of the Norwegian Sea: deployment of Steel Catenary Risers (SCRs) and reel-lay of Mechanically Lined Pipe (BuBi®) flowlines tying-back three subsea production templates to the SPAR.

Subsea 7's scope of work comprises engineering, procurement, installation and commissioning (EPIC) responsibility for the infield flowlines and steel catenary risers, and involves the procurement of Mechanically Lined (BuBi®) linepipe for the flowlines, the coating of linepipe for the flowlines and SCRs, as well as fabrication of all pipeline for reel-lay installation.

The infield pipeline system consists of four 12-inch outer diameter (OD) thermally insulated BuBi® pipe flowlines with a total length of 18km. One flowline runs between subsea locations while the other three run from subsea locations to the SPAR platform and are tied-in via 12-inch OD thermally insulated metallurgically clad pipe SCRs of approximately 2,000m length each.

The pipeline system also includes coating, fabrication and installation of one 14-inch OD corrosion protection coated carbon steel pipe SCR, approximately 2,000m long, for gas export.

All the SCRs, including fatigue zones, will be installed by the reel-lay method as part of the flowline installation campaign with *Seven Oceans* in 2015, and laid down temporarily for subsequent pull-in and hang-off after tow-out and mooring of the SPAR platform in 2016.

The 12-inch OD SCRs are connected to the flowlines by tapered transitions and welded connections.

SCRs in deepwater development can be subject to severe environmental loading, and the fatigue performance is often limited by the girth weld. Installation of SCRs by the reel-lay method has been demonstrated to be cost-effective. A significant benefit for SCR fabrication is that the majority of the girth welds can be fabricated and inspected onshore in a controlled environment, making it easier to ensure that the required high weld integrity is achieved.

The prerequisites for fabrication of SCR welds include:

- Close control of pipe-end tolerances and joint misalignment.
- High-integrity welding procedures.
- Flush grind of the weld caps to achieve the highest fatigue performance.

Subsea 7 has developed and qualified welding and inspection procedures which meet these exacting requirements, and can demonstrate a significant track record in successful production deployment for the fabrication of carbon steel and clad/ lined SCRs for reel-lay installation.

Subsea 7 also has EPIC responsibility for the rigid spools, monitoring system and strakes for the SCRs, protection structures and suction anchors for anchoring the risers and flowlines, as well as for the SPAR itself.

Further work includes the transportation and installation of control umbilicals, umbilical riser base, manifold structures, connections and pre-commissioning activities.



The contract also includes the transportation and installation of the mooring system for the SPAR buoy, tow-out of the SPAR, including hook-up of the mooring system and pull-in of the SCRs and dynamic umbilical.

The Aasta Hansteen field will be the most northerly development in the Norwegian Sea and will serve as a hub for future field developments in the area.

Subsea 7 will deploy various high-end pipelay, construction, flex-lay and survey vessels during the offshore period in 2015 and 2016, including *Seven Oceans* for the rigid pipelay, *Seven Pacific* for the umbilical installation and *Skandi Acergy* for the installation of large structures. Pipeline production of the SCRs and pipelines will take place at Subsea 7's spoolbase at Vigra, Norway.

The Aasta Hansteen award confirms Subsea 7's status as a contractor capable of delivering pioneering technology, and in particular transferring deepwater development experience gained in Brazil, West Africa and West of Shetland to emerging, harsh-environment regions like the Norwegian Sea.

To support this milestone project, Subsea 7 will also open a new office in Northern Norway.

For further information contact
Stian.Sande@subsea7.com

First deployment of unique By-Pass Purge welding system

Richard Jones, Welding Technology Manager

The Skuld project offshore pipelay operation for Statoil offshore Norway using *Seven Oceans* presented the first opportunity to implement the Subsea 7 Aquasol By-Pass Purge system for execution of the offshore tie-in welds. Performance of these critical welds is made difficult by the 'suck and blow' conditions within the pipeline which cause difficulties in creating an inert purge atmosphere needed to ensure the soundness of the girth weld.

The unique design feature of the By-Pass Purge includes a fully sealed enclosure to maintain the integrity of the purge gas together with a central vent which allows the draughts to pass through the pipeline without disturbing the internal purge gas.

The entire system is made uniquely of fully water-soluble materials, which enables the system to be flushed out on completion, and its design and materials are sufficiently robust to withstand the rigours of offshore operations. This innovative system significantly increases the reliability of offshore welding operations with better assurance of weld quality and minimal risk of extended vessel time.



By-pass purge enclosure in place

Welding advances in fabrication of metallurgically clad pipe

Last year saw the successful production deployment of Subsea 7's Pulsed Gas Metal Arc Welding (PGMAW) latest welding technology for the fabrication of metallurgically clad pipe in our reeled pipeline production facility in Vigra, Norway.

A key part of the welding solution is the use of the Controlled Metal Transfer (CMT) process for root welding. This is an advanced Gas Metal Arc Welding (GMAW) technique which allows the weld root to be deposited very precisely, giving good control of the root-based quality and profile. These are essential features to maintain the corrosion performance of the pipeline. Assurance of root weld quality is achieved by internal inspection using state-of-the-art camera and laser equipment.

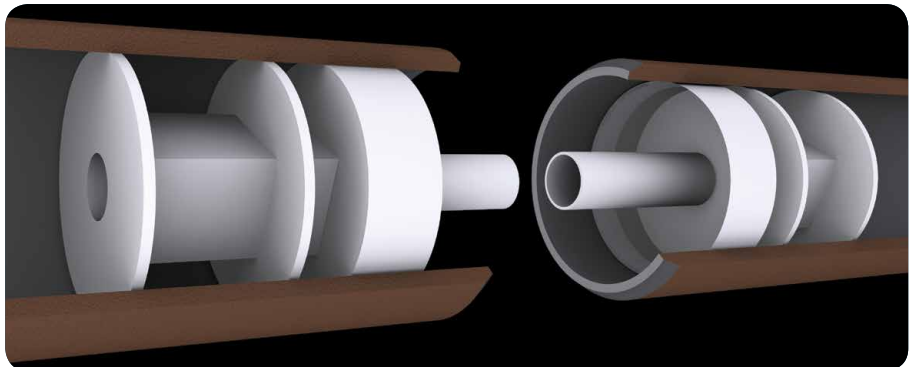

Subsea 7 Aquasol By-Pass Purge arrangement

The Vigra 2012 clad pipeline campaign involved four projects for Statoil - Visund Sor, Stjerne, Tordis and Skuld. The total length of pipeline fabricated exceeded 60km and pipe dimensions ranged from 10-16-inches OD with WT in the range 16-25mm. The linepipe comprised Grade 415 (X60) with 3mm 316L lining.

During the course of the fabrication, the laser/camera inspection reject

rate for the final project was less than 1.4%. Of particular significance was the Automated Ultrasonic Testing (AUT) rejection rate on final inspection procedures which was kept at a constant low level through the fabrication campaign at a typical level 0.2%. The overall successful completion of the 2012 clad pipe fabrication campaign is testament to the reliability of the development CMT/PGMAW solution.

Global Pipeline Welding Development Centre fully operational

2013 saw the completion in Glasgow, UK, of Subsea 7's new Global Pipeline Welding Development Centre, managed by the company's Pipeline Production Group (PPG). This new facility considerably enhances our capacity to provide leading-edge welding solutions for the full range of pipeline fabrication requirements.

The new centre incorporates 18 welding bays and supporting cutting and bevelling facilities to perform pipeline welding and testing for spoolbase welding and vessel tie-ins, as well as simulations for our S-lay and J-lay vessels.

The existing development centre has been re-configured to provide advanced NDT capabilities as well as dedicated R&D facilities. A major advantage of the new centre will be its capability to simulate the production firing line. This will allow PPG to perform realistic pre-production welding trials and operator training, which will facilitate the efficient transfer of technology to our fabrication sites worldwide.

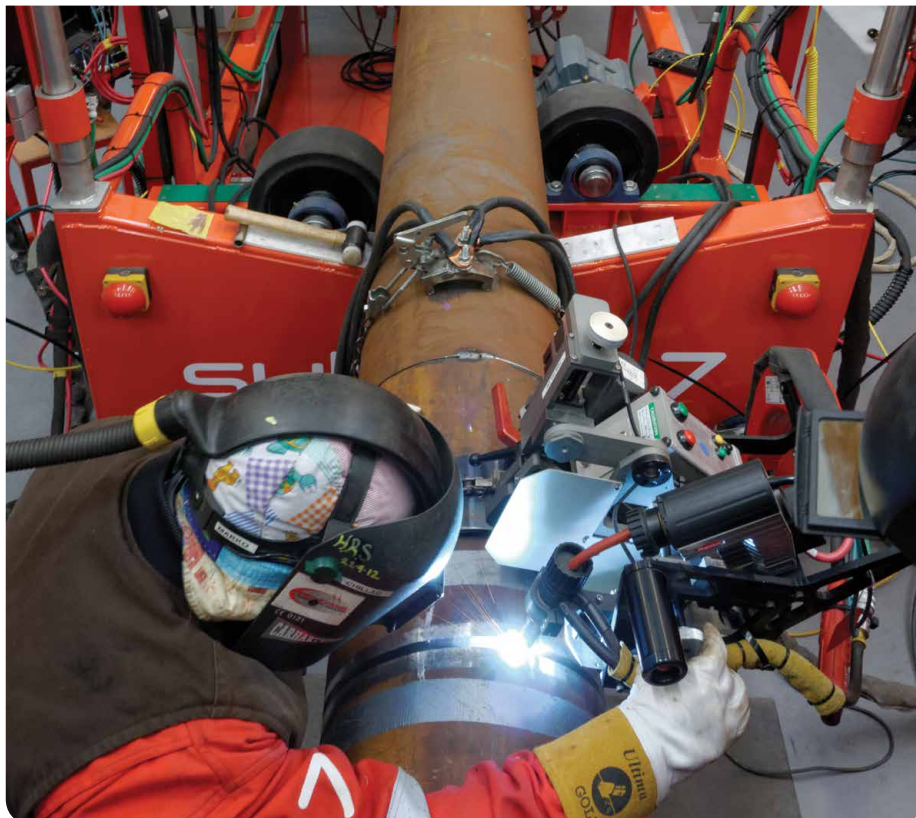

Global Pipeline Welding Development Centre

Welding qualification for reelable high-strength steels

There is increasing demand for pipeline installation, including SCRs, in deeper water, coupled with a requirement for higher operating pressures and temperatures and the need to transport corrosive constituents.

For such applications, the use of high-strength steel, Grade X80, offers significant benefits including a reduction in pipeline weight and savings in material and fabrication costs.

Reel-lay offers a cost-effective offshore installation method for high-strength steel pipe, although to date this has been limited to Grade X65/70 strength pipe.

Subsea 7, in collaboration with Vallourec and Mannesman Tubes, has performed a qualification programme for reelable X80 linepipe. In this programme, V&M Tubes manufactured seamless X80 pipe of 323.9mm OD x 18mm WT pipe in accordance with DNV OS-F101, supplementary P requirements.

Subsea 7 developed and qualified a mechanised girth weld procedure based on the GMAW-CMT/PGMAW welding process. Procedure qualification was successfully performed in compliance with DNV OS-F101, including mechanical, fracture toughness and sour service testing.

The development of linepipe material and welding solutions for reelable high-strength carbon steel are considered to be key enabling technologies for the exploitation of deepwater oil and gas reserves in the future.

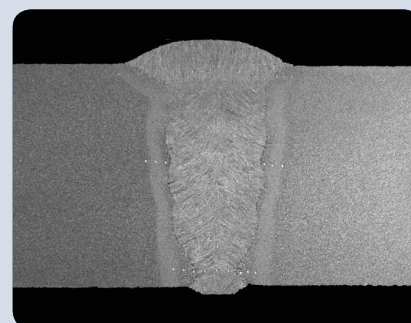

High-strength steel weld detail

For further information contact Richard.Jones@subsea7.com

Bundle technology: the next generation

Sam Watt, Senior Development Engineer

For over 30 years, Subsea 7 has been designing, fabricating and installing Bundles (towed pipeline production systems) from our fabrication facilities at Wick, in the North of Scotland.

With over 70 Bundles installed to date, this concept is a well-established and attractive alternative to individually laid flowlines in the development of difficult fields.

The concept

A flowline Bundle consists of a carrier pipe within which a combination of individual flowlines and umbilical components are housed, terminating in towhead structures at each end, which can include elements required for subsea production, such as valves and controls.

By filling the carrier pipe and towhead tubular sections with nitrogen and attaching ballast chain at regular intervals along the Bundle, the submerged weight is trimmed to enable the Bundle to be towed at a controlled depth. This towed production system also eliminates the requirement for heavy-lift vessels.

The advantages

Longer tie-back distances, greater fluid temperatures and pressures, heavier and more corrosive fluids, deeper water and harsher environmental conditions are all technological challenges which can be met by Bundle technology:

- BUTTING's BuBi® CRA-lined pipe offers significant cost savings compared to metallurgically clad or solid CRA linepipe.
- Highly efficient insulation systems and active hot water-heated or Electrically Trace Heated Bundles allow longer tie-back distances and development of fields with heavier fluid compositions.
- Bundle systems are considered the optimum design for HP/HT fields as



56-inch Bundle carrier pipe

the design permits flowline expansion along its entire length, reducing build-up of axial forces and the susceptibility to upheaval buckling. At present, the highest design temperature for a Bundle system is 160°C.

- There is a significantly reduced soils risk with Bundles with no individual pipelines to trench and bury, reducing project CAPEX uncertainty.
- Much of the subsea infrastructure can be pre-commissioned and tested as an integrated system while onshore.
- Bundles can usually be installed nearby or pulled under existing platforms, drill rigs or other offshore installations.
- There is generally no requirement for heavy lift vessels as subsea structures can be incorporated within the Bundle system. The heaviest towhead structure installed to date weighed approximately 525t, for Total's Jura project.

For further information contact
Sam.Watt@subsea7.com

The next generation

- Advances in Bundle design and analysis can further advance its suitability to HP/HT developments. Flowline pre-tensioning is one potential enhancement, where the Bundle fabrication is designed to 'lock-in' tension within the inner flowlines, reducing the propensity to expand under temperature and pressure.
- Deeper water is a challenge for Bundle design, since it places considerable demands on the collapse resistance of the carrier pipe and the internal nitrogen pressures. The greatest water depth for a Bundle design to date is 410m, for BG's Knarr development, but it is expected that this can be extended in the future by the use of alternative buoyancy arrangements.
- The length limit for a single Bundle at our Wick facility is approximately 7,600m; for longer tie-back distances, multiple Bundles connected in series are required. BP's Andrew project in the North Sea utilised four Bundles to span a distance of 27.8km. Options are currently being considered to increase the maximum achievable length of a single Bundle.
- The largest carrier pipe diameter specified for a project is currently 56-inches, for Total's West Franklin development. The launchway is expected to cope with carrier pipes up to 60-inches in size.
- The application of Bundles in far north fields is currently being considered, with a study assessing the feasibility of installing a Bundle in the Barents Sea, approximately 2,000km from Wick, where soil conditions are extremely challenging due to historic iceberg scarring.
- Health monitoring systems are becoming available which allow corrosion, erosion, blockages and leaks to be monitored in real-time. Incorporating these systems into Bundles will enhance Subsea 7's Life-of-Field capabilities.

We believe that Subsea 7's Bundle technology will continue to play a key role, both in the North Sea and progressively further afield.

Development of high-strength Mechanically Lined Pipe by reel-lay

Grégory Toguyeni, Senior Welding & Materials Engineer

The successful collaboration between Subsea 7 and manufacturer BUTTING has already led to the world's first qualification of the use of Mechanically Lined Pipe for reel-lay installation of flowlines and risers globally, as a cost-effective alternative to solid corrosion-resistant alloys or metallurgically clad pipe.

Further broadening of the technology has been undertaken in order to expand the application of Mechanically Lined Pipe to larger pipeline diameters, higher fatigue requirements and material grades.

As part of the qualification programme, comprehensive fatigue testing performed on previously reeled X65 pipe mechanically lined with Inconel 625 has demonstrated high fatigue performance up to DNV class C, thus allowing more flexibility in SCR design criteria and the use of this product to even greater water depth.

Subsea 7, Vallourec and Mannesman Tubes and BUTTING have collaborated to bring to the market an X80 grade BuBi® Mechanically Lined Pipe.

Recent development work has demonstrated the viability of high-strength Mechanically Lined Pipe for installation by reel-lay, allowing a reduction of the pipeline weight and its application to high-pressure, high-temperature conditions. Additional advantages of the use of high-strength

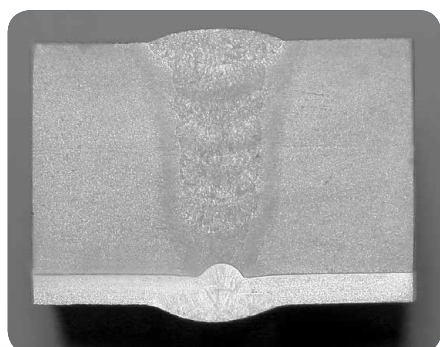

Internally welded root weld detail

grades for the carbon steel outer pipe are a reduction in buoyancy module requirements and the possible pipeline installation by existing pipelay vessels which would otherwise require increased top-tension capability for deepwater installation, if lower strength pipe was used.

The top-tension reduction will also be of significant benefit to the project host facility.

The high-strength development programme had a number of key objectives:

- To demonstrate the pipe mill and BUTTING can manufacture high-strength lined pipe to the same reeling specifications as for lower grades.
- To develop a welding procedure satisfying the quality and mechanical property requirements associated with reel-lay installation.
- To demonstrate that the global plastic deformation associated with reeling was not detrimental to the acceptability of the installed lined pipe.

Results to date have successfully demonstrated that:

- V&M can manufacture the X80 grade carbon steel to the appropriate specification in terms of DNV SMLS 555 suitable for reeling.
- The BuBi® liner assembly at BUTTING and the pipe-end seal weld/weld overlay arrangement met the required quality.
- Subsea 7 can apply the required girth welding technology to construct the pipeline and meet all the demands of the reeling process.

One of the key technical challenges is the requirement to have the strength of the girth weld exceed that of the carbon steel pipeline material.

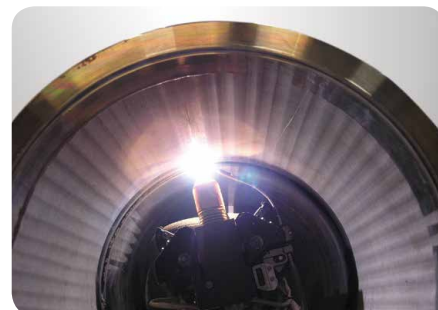

Internal welding

Conventionally for X65 carbon steel Alloy 625 can be used as the welding consumable and the overmatching strength achieved. In the case of X80 grade, Alloy 625 weld strength is lower therefore this option is not available.

Subsea 7 has therefore developed an innovative welding solution which was qualified in compliance with DNV welding requirements. This solution is based on an internally welded alloy 625 root weld and an external carbon steel weld.

This combination has demonstrated that the corrosion resistance, high-strength and toughness requirements can be met.

The reliability of this test programme has demonstrated the successful combination of BUTTING's BuBi® pipe technology and Subsea 7's pipeline design, fabrication and installation capabilities.

This market recognition contributed to the award of the Guar-Lula NE project by Petrobras in Brazil, where it is intended to deploy 70km of 8-inch BuBi® pipe by Subsea 7's *Seven Oceans* reel-lay vessel, and by Statoil for the Aasta Hansteen project, which includes the design, coating, fabrication and installation of 19km of 12-inch BuBi® lined pipe flowlines.

Full-scale reeling trial

Subsea 7 has recently successfully performed a full-scale reeling trial on the *Seven Oceans* reel-lay vessel at the Vigra spoolbase in Norway, where all aspects of the BuBi® pipe installation and emergency abandonment procedures were demonstrated.

For further information contact Grgory.Toguyeni@subsea7.com

Fleet development update

Subsea 7's fleet of over 40 vessels includes a number of industry-leading, high-performance vessels which have been specifically designed to meet client requirements for vessels capable of executing ever-larger, more complex projects at greater depths and in harsher environments.

We have invested over \$3 billion in our fleet development programme during the last five years, including *Seven Borealis*, the largest capital investment project ever undertaken by Subsea 7 at approximately \$550 million.

Seven Borealis was delivered on schedule during 2012 to Total's CLOV Project, offshore Angola, where the vessel is already utilising Subsea 7's latest mechanised welding technologies on its J-lay firing line.

Other recent additions to the fleet emphasise our commitment to giving our clients access to market-leading vessels with the highest standards of versatility and project reliability: *Seven Viking*, custom-built for all-year-round IMR operations in harsh marine environments, and *Seven Waves*, a high-performing flexible PLSV for the Brazilian market.

Seven Borealis

Seven Borealis is Subsea 7's flagship pipelay/heavy-lift vessel, with a number of innovative, custom-designed components for its 600t tension S-lay system (up to 46-inch pipe diameter utilising three tensioners) and 937t top tension J-lay system (up to 24-inch pipe diameter).

The tensioners, stinger and stinger support frame were all specifically designed for the vessel, and the S-lay system offers great flexibility in how the firing line is configured and the types of pipelines the vessel is capable of handling, as well as feeding the J-lay system.

Seven Borealis also features anti-heel and anti-roll systems designed to ensure a stable working environment even during delicate pipelay operations in challenging sea states and while working with heavy loads.

On a vessel with a 5,000t mast crane, the offset loads can be significant, so *Seven Borealis* features five pairs of ballast tanks which can accommodate water transfers at up to 13m³ per minute to keep the vessel balanced.

A "passive" roll-damping system is also incorporated to reduce the roll motion induced by heavy sea states. This is based on four large flume tanks filled to ensure the water level is in anti-phase to the ship's roll, and creating a damping effect on the motion.

In optimum conditions, the tanks can reduce the roll by around 40% and greatly enhance the operability of the vessel.

The 5,000t mast crane, with the top of its mast reaching 150m above the main deck, is the world's largest offshore mast crane, and gave an early demonstration of its capabilities in the installation of the 1,630t J-lay tower.

An equally impressive installation lift was the 385t lift of a stinger section at a radius of 104m.

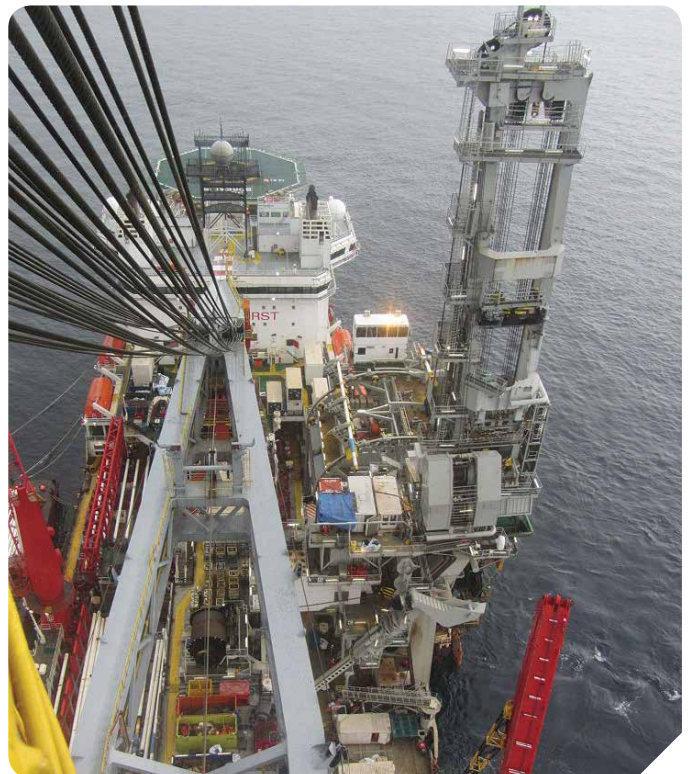

Seven Borealis also features a 600t A&R winch utilising 135mm diameter wire for 3,000m water depths, a 1,200t heave-compensated auxiliary hoist and incorporates 2,400t onboard pipe storage.

This flagship vessel is one of Subsea 7's highly versatile global enablers, capable of meeting exacting heavy lift and pipelay requirements in the deepest and most harsh environments.

For further information contact Ben.Moffat@subsea7.com

Seven Viking

In early 2013, the new-build *Seven Viking* entered a long-term contract with Statoil for Inspection, Maintenance and Repair and light construction operations in the North, Norwegian and Barents Seas. The robust, specialised vessel is designed for operation in harsh environments, and features ICE-C classification and a compact design that reduces motion in transit, gives increased stability and enhances manoeuvrability.

Despite its compact size, the vessel draws on Subsea 7's extensive IMR experience to include an innovative configuration that maximises hull space and offers extended equipment and tool-handling capacity within a large heated indoor hangar area.

Among the many novel features designed to facilitate IMR operations in rough seas and extreme temperatures is a customised module-handling system (MHS) integrated in the hangar which enables the controlled launch and recovery of subsea modules up to 10m in height and weighing up to 70t through the moonpool in water depths up to 2,000m.

The MHS has two AHC lifting winches, one 70t and 2,000m and the other 20t and 1,000m. The system also incorporates an automatic prong/cursor system, operates up to 5m significant wave height and has possibilities for combined lifting.

To minimise working at heights and manual handling, man-riding lifts and utility cranes are also installed in the hangar area, and noise levels are minimised by the use of all-electric winches for the ROVs, the MHS and utility equipment.

The vessel's continuous skidding system has storage capacity for up to eight pallets, including four indoor storage positions. Twist locks are integrated into part of the 840sq.m working deck for quicker mobilisation and demobilisation of standard containers.

Seven Viking is another versatile, class-leading vessel to be added to the Subsea 7 fleet, and has immediately gone into all-year-round service in the challenging Norwegian waters for which she has been designed.

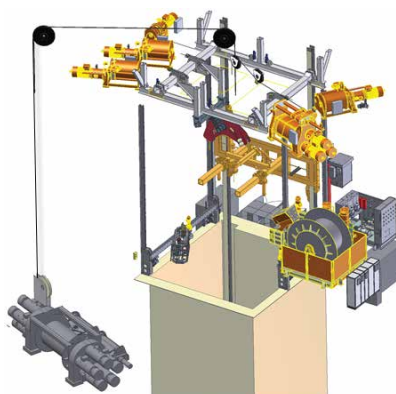

For further information contact Bjoernserck.Hanssen@subsea7.com

Seven Waves

Fabrication of the new-build flexible PLSV *Seven Waves* is now complete, with approximately 6,000t of steel on the berth in Holland prior to her launch in May 2013. By April 2013, 140km out of 300km of electrical cable had been pulled, and almost 11,000 of her 13,000 pipe spools installed.

The vessel is scheduled for delivery to Petrobras in 2014 on a long-term charter contract following her launch in May 2013 in Holland. Her sea-trials will take place in September 2013, following which her 550t Tilttable Lay System (TLS) will be installed, also in Holland.

The vessel's high-specification top-tension capability gives *Seven Waves* one of the highest-performing flexible pipelay capabilities in the world, reflecting the existing and anticipated requirements of Brazilian deepwater and ultra-deepwater operations.

The TLS incorporates two 275t retractable tensioners to handle flexible products between 100mm and 630mm outer



diameter. The tower can tilt to 10° when operational to recover rigid pipe from the seabed but it can also tilt to 50° from the vertical to allow the TLS to clear overhead cables at the entrance to Vitoria harbour in Brazil.

For further information contact Brian.Rice@subsea7.com

Heaviest and deepest subsea lifts

Marin Abélanet, Engineering Director, Asia, Australia and New Zealand

Subsea 7 has been awarded a contract by Chevron Australia for the Heavy Lifts and Tie-ins scope for the Gorgon Project, which is developing the Gorgon and Jansz-lo gas fields off the northwest coast of Western Australia.

The contract will see Subsea 7 deploying some of the largest and heaviest subsea structures in the industry to date.

At the Jansz-lo field, there are a total of six structures with a total weight in air of circa 3,500 tonnes which will be lowered to the seabed at an average depth of 1,300m.

In order to deploy these large structures safely and efficiently to the deepwater section of the Jansz-lo field, Subsea 7 is investing in a customised deepwater lowering system, which will be self-contained and mobilised as a single unit on board the heavy lift vessel *Sapura 3000*.

This lowering system comprises two identical capstan traction winches of



Deepwater lowering system

180t capacity, reeved in four falls with 6,000m of wire. It has a maximum dynamic capacity of 1,300 tonnes at 1,300m and will be delivered later in 2013.

The large structures will be offloaded from the transport barges using the vessel's 2,600t capacity main crane and transferred via a lowering beam to the Deepwater Lowering System. They will then be deployed directly in one single operation to the seabed.

This latest addition to Subsea 7's range of heavy lift subsea equipment

will open new opportunities for the deployment of larger, heavier elements of subsea infrastructure in future deepwater developments.

** The Gorgon Project is operated by an Australian subsidiary of Chevron and is a joint venture of the Australian subsidiaries of Chevron (47.3 percent), ExxonMobil (25 percent), Shell (25 percent), Osaka Gas (1.25 percent), Tokyo Gas (1 percent) and Chubu Electric Power (0.417 percent).*

For further information contact Marin.Abelanet@subsea7.com

Improving vessel utilisation

Subsea 7 is currently working on a number of new severe-weather technology initiatives to enhance operations in challenging sea states. One is a crane lifting aid under development by Subsea 7 designed to improve deck-handling safety during lifting and with the potential to significantly extend winter-weather operations in harsh waters like the Norwegian Sea.

The Universal Launch Assistant (ULA) is a load-controlling mechanical arrangement attached to the crane pedestal of existing vessels and controlled by the crane operator. Its telescopic arms swivel around the crane pedestal, and give firmer and safer handling of horizontal inertia loads including templates, manifolds and associated spools even in sea states above the current limiting range of 1.5-2m significant wave height.

The ULA replaces the use of winches with holdback wires which are conventionally used to control horizontal loads, and therefore enhances on-board safety as well as significantly improving the utilisation of vessels involved in construction work in challenging weather conditions.

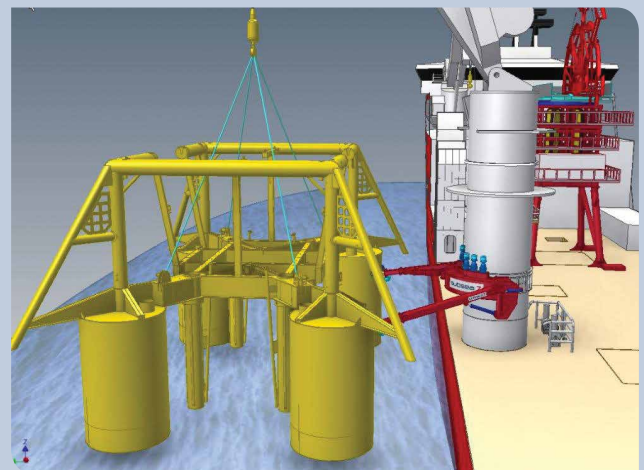

A traction ring and slider arrangement allows the main structure and the telescopic arms to swivel through 360° around the crane pedestal. The Master and Auxiliary telescopic arms extend and retract in order to reach the equipment on the deck and facilitate load damping, enhancing the operational efficiency of vessels involved in construction work.

For further information contact Sigbjorn.Daasvatn@subsea7.com

Autonomous intelligent inspections: a game-changing technology

Scott Cormack, Sales and Marketing Director,
Life-of-Field and i-Tech - Global

After five years of intensive prototype development, Subsea 7's pioneering Autonomous Inspection Vehicle (AIV) has recently undergone its final phase of verification trials in the challenging waters off Peterhead and Fort William, in Scotland.

Having now qualified its full system robustness, we will bring the Mark 1 AIV to market for commercial deployment later in 2013.

The AIV has been developed in collaboration with SeeByte, a leading developer of underwater robotic software, and the vehicle will change the way infield inspections, light intervention and environmental activities are delivered.

The vehicle's unique station-keeping and hovering ability represents the next step in the evolution of autonomous systems in the marine environment.

Operating directly and tether-free from an offshore host facility (FPSO, platform or support vessel), the first commercial AIV will be capable of regular inspections of risers, pipelines and seabed equipment.

A more rapid field assessment can be made using multiple systems operating together from a single support vessel. This capability has never been commercially available until now, and represents a truly game-changing technology for Life-of-Field operations.

Multi-vehicle "install and retrieve later" campaigns of this type can utilise a low-cost support vessel to optimise mission coverage, sending data onshore for processing, and carry out simultaneous field survey and inspection activities.

In order to balance performance with energy consumption, the vehicle hull shape was analysed and optimised using advanced Computational Fluid Dynamics (CFD). The Mark 1 AIV has a customised launch and recovery system

with an A-frame deployment basket.

Last year saw the final simulation phase of development, with hundreds of virtual AIV missions performed within a 3D offshore oilfield representation to ensure that the remote decision-making of the autonomous vehicle was robust. Since then, the software system has been further hardened to optimise the vehicle's dynamic ability to recognise subsea infrastructure environments, make optimum decisions and complete pre-planned missions.

The Mark 1 AIV can be utilised on single- or multi-vehicle campaigns or smaller packages of work, or deployed long-term on a platform or FPSO for ad-hoc or regular field inspections with no need for support vessel mobilisation. This latter scenario can benefit integrity management performance by the early identification of issues requiring remedial action.



AIV deployment system



In the longer-term, operators may also utilise the AIV's intelligent decision-making capabilities in a number of ways: to complement the pre-programmed activities of Autonomous Underwater Vehicles (AUVs), to build AIV compatible interfaces into subsea infrastructure design, to perform post-hurricane inspections or, looking further ahead, for deployment in future under-ice subsea developments.

System specifications

Depth rating	3,000m
Dimensions	1700mm (L) x 800mm (H) x 1300mm (W)
Weight in air	790kg
Endurance	24 hours, dependent on conditions
Maximum excursion	40,000m, dependent on conditions (ie currents)
Positioning accuracy	within 1.5-3m inspection range following seabed infrastructure
Inspection sensors	3D forward-looking sonar Colour inspection class video camera Profiling sonar and downward look camera
Comms	Acoustic in-water, Wi-Fi on deck, satellite for emergency location
Navigation	Dead reckoning (1% distance travelled) aided by sensor data and seabed markers

For further information contact Scott.Cormack@subsea7.com

Gateway to the Arctic

Subsea 7 has established its Arctic research competency in St. John's, Newfoundland and Labrador, whose icy offshore environment is classified as sub-Arctic.

Although not as challenging as the Arctic, the basins off the coast of Newfoundland, where current oil and gas resources are being exploited, have harsh metocean and ice conditions that are continuously changing. From intense winter storms to sea ice and icebergs in the spring, and heavy fog in the summer, this unique combination of environmental conditions has made the development of offshore energy resources very challenging.

St. John's, often referred to as the "Gateway to the Arctic", is already the focal point for offshore resource development in Canada, leading to the widespread establishment of Arctic research facilities in the area.

The sub-Arctic technology solutions developed in St. John's are likely to be transferable to more difficult Arctic regions as offshore development moves further north, and Subsea 7 is already working in collaboration with operator clients, local Arctic experts and dedicated research facilities toward identifying targeted Arctic challenges and developing research and technology development programmes to meet them.



For further information contact Dwayne.Hopkins@subsea7.com

Simultaneous dual pipeline installation

An innovative process which allows for the simultaneous pipelay of a flexible pipe or cable attached onto a more robust carrier pipe has been developed by Subsea 7 and successfully deployed for the first time in the harsh waters West of Shetland, where weather dependency is a major limiting factor to efficient pipelay operations.

The conventional process for such an operation is "piggybacking", a labour-intensive process involving manual blocks and banding procedures, which typically restrict pipe-laying speed.

In 2011, Subsea 7 first started work on developing a more efficient and safer solution – a semi-automatic process where operators did not have to work in close proximity to the moving pipelines, and where accelerated lay-rates would be possible.

This new system made its operational debut on Total's 142km Laggan-Tormore pipeline in 2012, on which Seven Oceans applied over 30,000 of the new clamps without impacting on the pipelay rate.

It is recognised that conventional banding has significant limitations for fast, automatic piggybacking, so, after detailed study of the installation and operational conditions, the developers decided to trial a semi-automatic machine which would simultaneously align the two pipes together and apply a new quick-locking block concept.

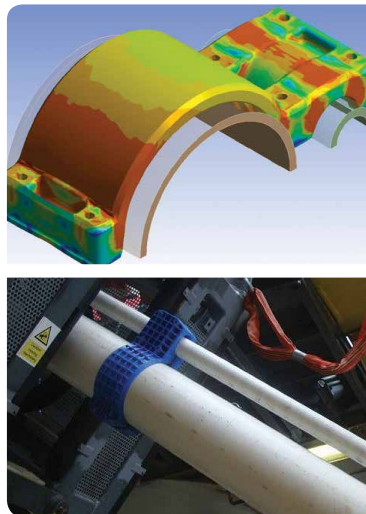

After intensive testing of the prototype clamps, a suitable material for the blocks was identified – a tough, inert, water-resistant plastic. A design was developed by which the two halves of the block could be quickly locked around the pipes by six quick-fastening, barbed stainless steel fixings.

The new system has a number of advantages – it is quick to apply, and can cater for a wide range of pipe diameters.

The robustness of the design is also advantageous when pipelines are pulled through a long conduit, as was the case with Laggan-Tormore. This procedure can damage conventional banding, but no piggyback clamps were lost during the system's inaugural deployment.

For further information contact Lee.Rolf@subsea7.com